

# Frameless Glass Cavity Slider

TRILINE ARCHITECTURAL CAVITY SLIDING DOOR SYSTEMS

TRILINE 2024



1300 239 206  
sales@triline.net.au

[linkedin.com/company/triline](https://www.linkedin.com/company/triline)  
[facebook.com/trilinequalitydoorsystems](https://www.facebook.com/trilinequalitydoorsystems)

@trilinedoors  
triline.net.au





# Index

## OVERVIEW

---

4-6 Introduction

---

7-9 Specifications

---

10-11 Elevations & Opening Preparation

---

12 Trim Options

---

13 Accessories

---

14-15 Project Feature

---

# Transform spaces. Embrace light. Redefine luxury with frameless glass sliding doors.

## **Designed to enhance the beauty of every space**

Welcome to the future of interior design. Our frameless glass cavity sliding door system introduces a new era of elegance and functionality to modern architecture. Crafted with precision engineering and attention to detail, these doors seamlessly blend into high-end luxury dwellings, offering both aesthetic appeal and practicality.

We have incorporated the European-designed and made Saheco sliding glass clamp system into our frameless glass cavity sliding door solution. This system requires no machining of the glass for mounting, offering a truly minimalist approach with its compact size and decorative cover plate. The Saheco system stands out for its easy front-facing installation, making it a practical and aesthetically pleasing choice for modern architectural projects seeking seamless integration of frameless sliding doors.



# What are Frameless Glass cavity sliders?

Imagine a door that appears to float effortlessly. Our frameless sliding doors, made from 8-10mm thick tempered or laminated glass, exude sophistication without the need for visible frames. This minimalist design choice opens up spaces, allowing natural light to cascade through rooms and enhancing the overall ambiance.



# Why Frameless Glass door systems?

Whether you're designing a luxurious residence, upscale retail space, or contemporary office environment, our frameless glass cavity sliding door system is the epitome of modern sophistication. Elevate your architectural projects with our innovative solution, designed to inspire and enhance the beauty of every space.

Floor-to-ceiling sliding panels, especially when crafted from glass, enhance open-plan interiors by allowing daylight to flood rooms. This not only enhances aesthetics but also improves the functionality of spaces, reducing reliance on artificial lighting and creating a more comfortable environment for occupants.

---

## SEAMLESS DESIGN

Frameless construction provides a sleek, contemporary look that complements upscale interiors.

---

## ABUNDANT NATURAL LIGHT

Enhance open-plan layouts by maximizing daylight penetration, reducing the need for artificial lighting during the day.

---

## DURABLE AND SAFE

Built with toughened glass, our doors ensure safety without compromising on style.

---

## CUSTOMIZABLE FINISHES

Choose from clear, translucent, or custom finishes to match any design vision.

---

IN DETAIL

# Triline Frameless Glass Cavity Slider

Frameless glass doors offer architects and designers a sophisticated solution to elevate modern design projects. By incorporating these doors, spaces are transformed with abundant natural light, creating an uplifting and inviting atmosphere. Unlike traditional doors, frameless glass doors seamlessly blend into the architectural setting, adding elegance without overpowering the space.

Architects and designers can leverage the versatility of frameless glass doors to achieve a contemporary and refined look, giving them a competitive edge in creating exceptional and inviting spaces.

## FEATURES



### Clamp System

Clamp mechanism attaches to the glass top without holes or cut-outs, ensuring seamless installation.



### Door Weight

Standard carrying capacity is 90kg. 120kg available upon request.



### Sophistication

Frameless construction provides a sleek, contemporary look that complements upscale interiors.



### Customizable Finishes

Choose from clear, translucent, or custom glass finishes to match any design vision.

IN DETAIL

# Specifications

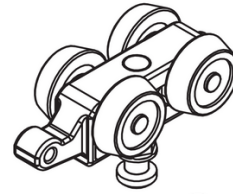

Max Door Weight	90kg, 120kg on request
Soft Close Option	Yes
Max Door Height	2700mm
Max Door Width	1500mm
Clamp Height Above Glass	21mm
Clearance Above Door	4mm
Clearance Below Door	13mm
Suitable for Full Height Doors	Yes
Engineered for Wall Tiles	Yes

\*\*Note: max door height & width may vary depending on the weight of the door.



IN DETAIL

# Specifications

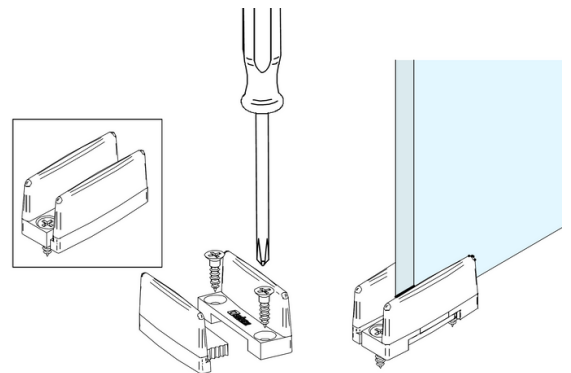
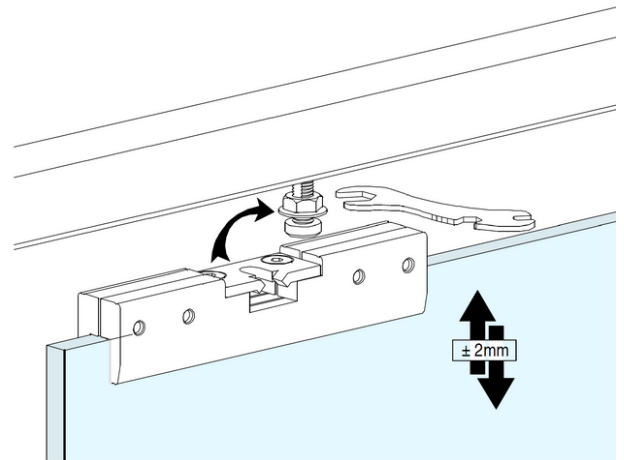
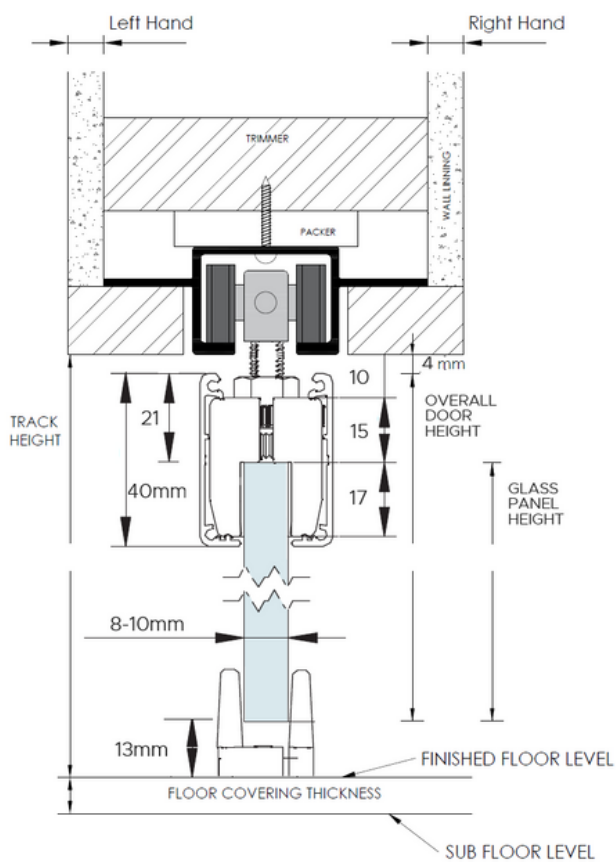

The Frameless Glass cavity system is suitable for single doors sliding to one side or double doors sliding either side on a single track.

The Frameless Glass cavity slider allows for simple height adjustment, by simply raising or lowering the hanger bolt.

# Elevations

FRAMELESS GLASS CAVITY SLIDER  
LESS THAN FULL HEIGHT (WALL ABOVE)

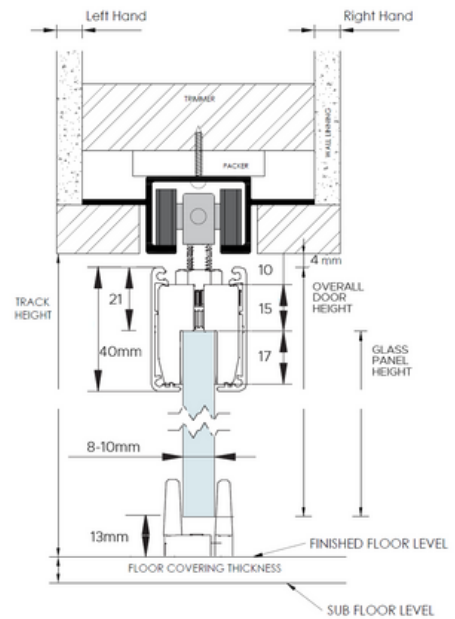

FRAMELESS GLASS CAVITY SLIDER  
FULL HEIGHT (FLOOR TO CEILING)

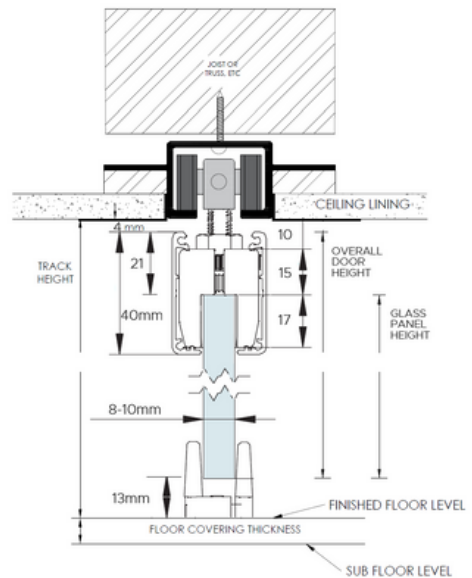

# Opening Preparation

Frames are designed to sit on to the floor surface (i.e. concrete/timber) before floor coverings.

## DOOR CLEARANCES

Between track & door: 4mm  
Below door: 13mm

---

## SINGLE DOOR OPENING

Opening Width (Stud to Stud):  $2 \times \text{door width} + 60\text{mm} - \text{Door Projection}$   
Opening Height (Floor to Trimmer):  $\text{door height} + 57\text{mm} + \text{Floor Covering}$

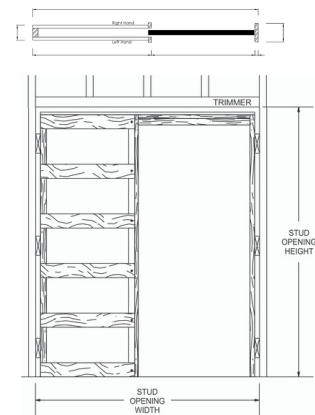

---

## DOUBLE DOOR OPENING

Opening Width (Stud to Stud):  $4 \times \text{door width} + 60\text{mm} - (2 \times \text{Door Projection})$   
Opening Height (Floor to Trimmer):  $\text{door height} + 57\text{mm} + \text{Floor Covering}$

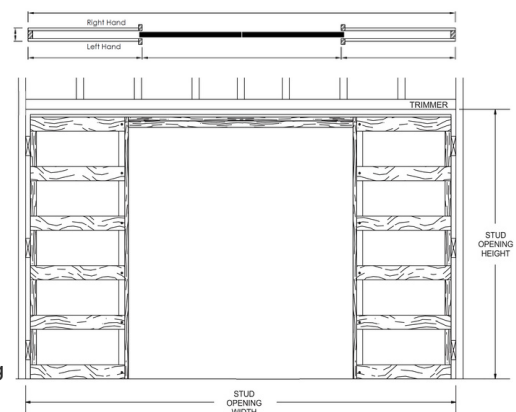

# Trim Options

---

## ARCHITRAVES

This is our standard setup for our cavity units. Split jambs, heads and closing jamb are all made to be fitted with architraves (supplied by others). Architrave height also matches standard swing door architrave height to create a seamless look when side by side.

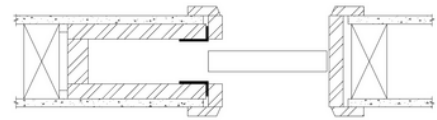

---

## EZYJAMB CAVKIT

Manufactured from high-performance steel, the metal frames trim and cap the plaster edges around the door penetration. The cavity jambs are made smaller than standard for ease of wrapping over plasterboard. Triline can supply our purpose made EzyJamb flush finish system to suit your cavity slider to streamline your installation process.

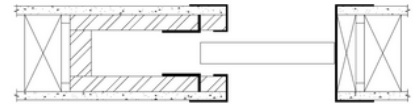

---

## P25 STOPPING ANGLE

The jambs are all made 3mm wider to sit flush with the P25 angle (supplied by others) once this has been troweled in and painted to ensure a clean square stop finish to the door jamb.

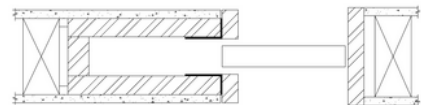

---

## P50 SHADOW LINE

Also requires the jambs to be made slightly wider to align with the metal P50 shadow line angle (supplied by others). This unique shadow line adds another whole dimension to the aesthetics of your doorway.

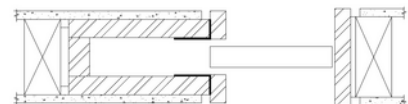

# Accessories

## Engineering & Certification

All Triline cavity sliders up to 2400 x 1200 are certified to carry floor to ceiling tiles as per the Prototype Test requirements outlined in AS 1720 Timber Structures—Design Methods.

See our brochure for further details on Total Equivalent Test Load and recommended installation combinations.

Sustainability is important to us and that is why when manufacturing the cavity units we do our best to get materials supplied in set lengths to minimise waste and increase productivity.

We love to create beautiful sliding door solutions that feel like an experience and are manufactured through efficient practices

---

## Soft Close

The mechanism catches the moving door and reduces its speed before drawing it towards the jamb ensuring a quiet and soft stop every time. This reduction in speed also means little fingers are kept safe from slamming doors.

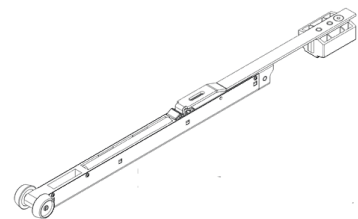

---

## Cavity Switch Unit

Rangerbuilt cavity switch unit is an innovative new product that allows the installation of light switches and power points onto a wall with a cavity sliding door unit or commonly known as a pocket door.

With Rangerbuilt cavity switch, electrical wires are protected from the movements of the door enabling you to utilise the walls on either side of your sliding door unit for all your electrical needs.







Enhance  
Your  
Vision with  
Frameless  
Elegance





triline.  
net.au

Head Office/Factory  
86 Sunderland Street  
Derwent Park TAS 7009

Sunshine Coast Factory  
4 Railway Court  
Glanmire QLD 4570

1300 239 206  
sales@triline.net.au

[linkedin.com/company/triline](https://www.linkedin.com/company/triline)  
[facebook.com/trilinequalitydoorsystems](https://www.facebook.com/trilinequalitydoorsystems)

@trilinedoors  
triline.net.au