

Maximum door weight:

- 80kg as standard
- 120kg & over - optional

Frames are designed to accept a standard door thickness of 35mm, however 90mm and 100mm frames can be made to accept thicker doors.

Use of 70mm and 75mm frames is not recommended for bathrooms and laundries where moisture may cause the doors or rails to warp.

Frames are available for the following door sizes and wall (stud) thicknesses, (90mm standard).

DOOR HEIGHT	DOOR WIDTH	WALL (STUD) THICKNESS
2040mm	620, 720, 770, 820, 870	70, 75, 90 and 100mm
2040mm	920mm and wider	Only 90 & 100mm are recommended
Over 2040mm	As required	Only 90 & 100mm are recommended

Note that frames for doors over 920mm wide or over 2040mm high or over 35mm thick and for special stud thickness, are made to order.

1. CHECK

Check that you have purchased the correct Cavity Door Frame for your unclad wall (stud) thickness, lining thickness, door size and door thickness. The design allows for the door to slide into the frame and be flush with the split jambs.

(Fig. 1)

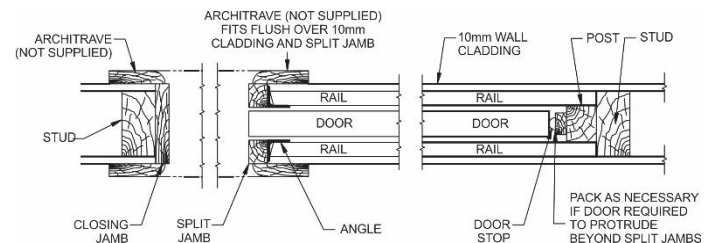

Figure 1

If you require the door to project into the opening when fully open, pack behind the door stop on the post or install a wider door.

2. PREPARE OPENING

Opening width (stud to stud) (Fig. 2)

Single door: Door width x 2 + 60mm (for door flush with split jambs)

Double door: Door width x 4 + 60mm (for doors flush with split jambs)

Opening height (floor to trimmer) = door height + 75mm

Frames are designed to fit onto the floor surface (i.e. concrete/timber) before floor coverings.

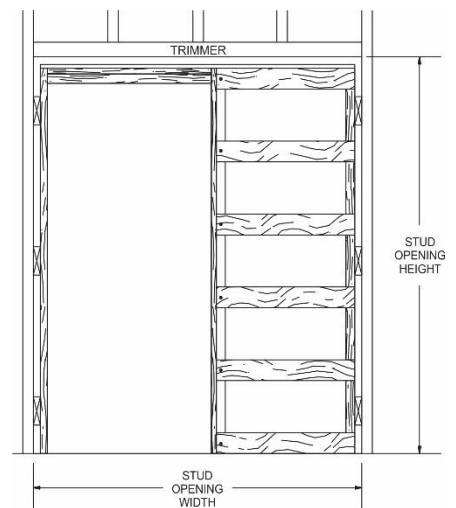

Figure 2

3. CLEARANCE UNDER THE DOOR

The clearance under the door is adjustable from approximately 10 – 20mm. This gap may be taken up by floor covering e.g. carpet, tiles, vinyl etc. If you require more than 20mm clearance under the door, pack the cavity door frame off the floor by the required amount.

4. ASSEMBLE FRAME

The aluminium head-track is to be screwed down to the top of the frame with the split head against the split jamb. Cut the closing jamb to the exact length you require, then screw it to the underside of the aluminium head-track against the split head.

(Fig. 3)

The frame must be installed with the head-track level. Screw the head-track to the trimmer through the holes in the centre of the track.

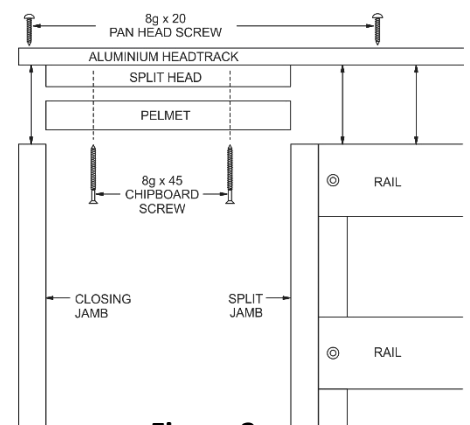

Figure 3

DOOR INSTALLATION

5. **INSTALL FRAME**

Ensure that the floor is level beneath the frame. Place frame into opening, ensuring that it is square, plumb and level. Pack as necessary between POST and STUD and fix off to framework and floor.

6. **FIT HANGER PLATES**

Fit hanger plates to the top of the door, 70mm in from either end, with the slots both on the same side of the door. (Fig. 4)

7. **HANG DOOR**

Insert wheels into the track. Place the door in line with the track and insert hanger bolt head into the slot in the hanger plate. Adjust bolt to height required and tighten the lock nut to secure the bolt.

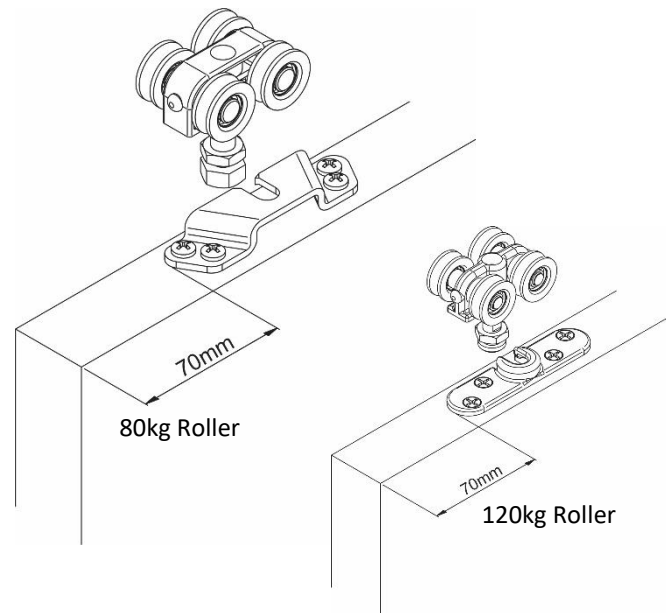

Figure 4

We recommend you hang the door temporarily before the plaster board is clad to make sure the cavity slider fittings are correctly installed. However, we recommend that you remove the door again before plaster board is clad and only rehang the door when plaster is dry and the door has been completely sealed and painted.

8. **FINISHING**

Position the CLOSING JAMB to suit the door when closed, then pack and secure the closing jamb in place.

9. Nail the fixed pelmet to the split head between the split jamb and closing jamb. Fit the removable pelmet with the screws provided, on the same side as the slots on the hanger plates.

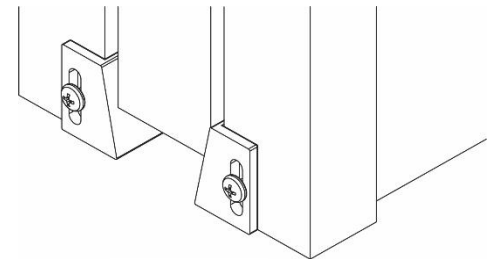

Figure 5

10. **GUIDES**

Screw the wedge guides to the split jambs and adjust vertically so that the door can move freely between the guides. (Fig. 5)

11. **ARCHITRAVES**

Once the wall has been clad, fit architrave around the jambs and split head, being careful that nails do not penetrate through rails.

12. **TO REMOVE DOOR**

The door can be removed by reversing procedures 10, 9, 7 & 6.

13. **DOUBLE DOOR INSTALLATION**

Assemble frames and install as per steps 4, 5, 6 & 7. Double units come standard with one-piece double head-track and two track-stops. (Fig. 6) Double frames must be level, plumb and checked for alignment (no twist) so doors line up in the closed position.

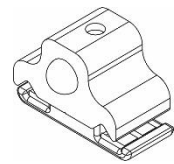

Figure 6

CHECK DOOR OPERATION BEFORE THE FRAME IS CLAD

Once the doors are installed, position the track-stops in the head-track where the doors meet, so that neither of the doors slide fully out of the cavity, past the guides. Once they are in place tighten the screws to secure.

PRODUCT IMPROVEMENT IS A CONTINUOUS PROCESS & SPECIFICATIONS ARE SUBJECT TO CHANGE WITHOUT NOTICE

© COPYRIGHT TRILINE 2020 E & OE

Head Office/Factory
86 Sunderland Street
Derwent Park TAS 7009

Tel: 1300 239 206
Email: sales@triline.net.au

Queensland Office/Factory
4 Railway Court
Glanmire QLD 4570

Tel: 07 5481 2336
Email: qldsales@triline.net.au

 www.triline.net.au

 trilinequalitydoorsystems

 Triline Quality Door Systems