

# Slido D-Line43 80M

INTERNAL SLIDING DOORS



TRILINE 2023

1300 239 206  
sales@triline.net.au

@trilinedoors  
facebook.com/trilinequalitydoorsystems

triline.net.au

**triline**

SLIDO D-LINE43 80M

## Unveil invisible elegance with up to 80kg door weight capacity, noiseless glide, and 1100mm concealed track.

Introducing the revolutionary Slido Design 80-M Sliding Door System - where architectural minimalism meets unparalleled functionality. Embark on a journey to transform spaces with the magic of invisibility and the grace of modern design. Crafted for those who seek the perfect blend of aesthetics and performance, the Slido Design 80-M redefines sliding door solutions.





Designed to seamlessly integrate into various environments, the Slido Design 80-M is the epitome of hidden elegance. Its concealed running system merges with the architectural elements of your space, creating an aura of minimalism that captivates every eye.



Slido D-Line43 80M

## FEATURES

---

	Door Width	800mm Min. 1800mm Max.
	Door Thickness	Min. 30mm
	Door Weight	Max 80kg
	Suitable For	Hard floors (laminare, PVC, tiles) and soft floors (carpet, cork - use only with floor rail)
	Door Type	Wooden Sliding Doors

---

## Slido Design 80-M

Our Slido Design 80-M sliding door system celebrates the art of minimalism. Experience a world where form and function harmonize, and elegance finds expression in the invisible.

Discover a symphony of design that transforms your space into a canvas of sophistication.

Unleash the potential of architectural minimalism with the Slido Design 80-M Sliding Door System - where every slide narrates the story of innovation, elegance, and seamless design. Elevate your spaces today.

## What are the benefits?

### Ease of use

- Easy surface-mounted smooth sliding mechanism
- Simple wall installation process with concealed components
- Noiseless operation
- Accommodates wooden doors up to 80kg providing flexibility in design

### Aesthetics

- Invisible Elegance: Concealed running system creates a visually stunning, unobtrusive appearance.
- Architectural Minimalism: Integrates seamlessly with modern spaces, enhancing clean and simple designs.
- Floating Illusion: Doors appear to effortlessly float along walls, adding a touch of enchantment.
- Modern Innovation: Incorporates cutting-edge technology into classic door functionality.

### Track Systems

To suit door panels 800-1100

To suit door panels 1101-1800



## Unveiling Architectural Elegance

Imagine doors that appear to float effortlessly, as if guided by an invisible hand. Our innovative Slido Design 80-M is engineered to fulfill this vision, enabling one-leaf wooden sliding doors to slide along walls with seamless grace. This ingenious concealed running system eliminates the need for traditional top tracks, leaving your interiors uncluttered and visually stunning.

## Set Includes

- A. Running Track - mounted to back of door
- B. Running Gear - mounted to wall
- C 2 x Soft Close Mechanisms
- D. Guide Track - mounted to bottom of door
- E. Floor Guide
- F. Set of Guide Rollers
- G. Set of End Caps
- H. 2 x Spacers
- I. Floor Mounted Door Stop (Optional)

2 x Hex Keys  
1 x Open Ended Spanner

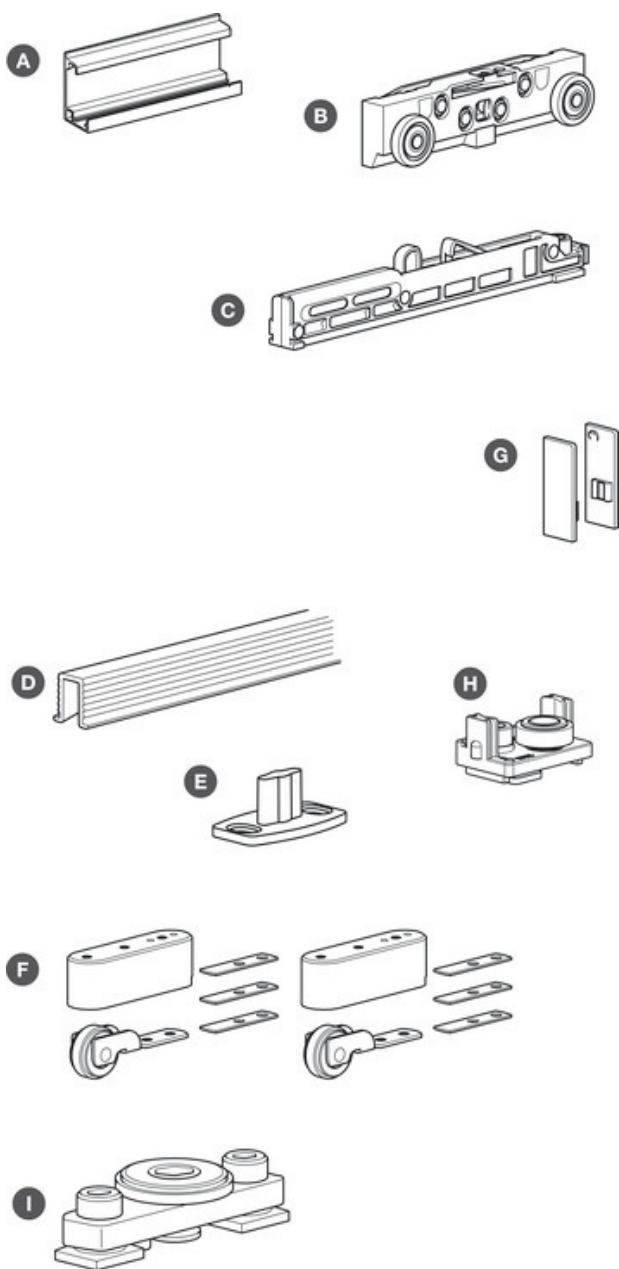

# Technical Drawings

## Door Installation

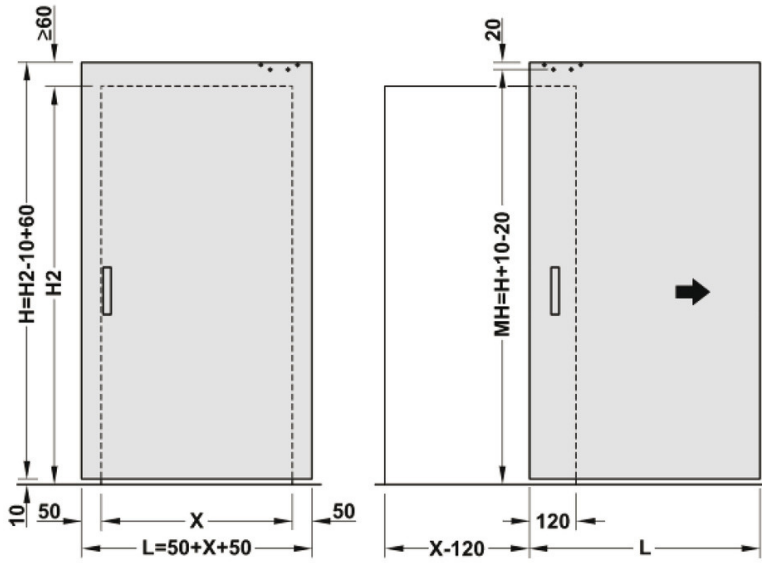

## Wall Mounting

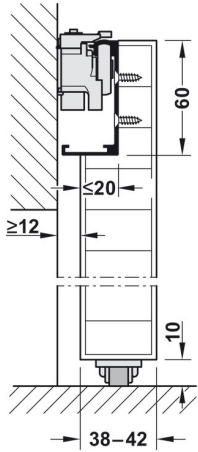

Floor Guide on Hard Floors

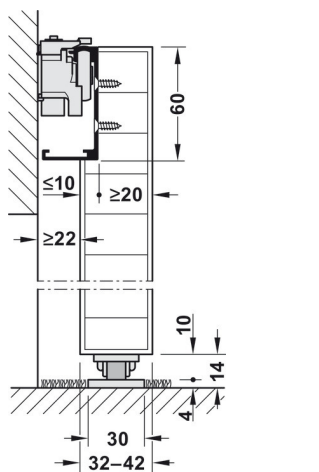

Floor Guide on Soft Floors with Running Track Provided on Site

## Section Running Gear and Floor Guide

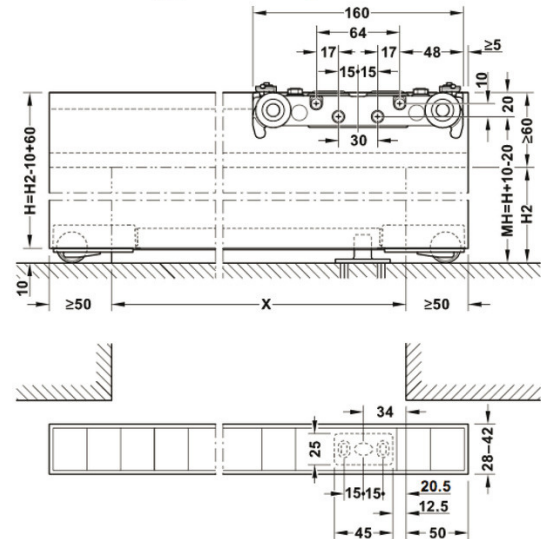

H = door height  
MH = installation height

H2 = internal opening height  
X = internal opening width

## Cut-out Dimensions

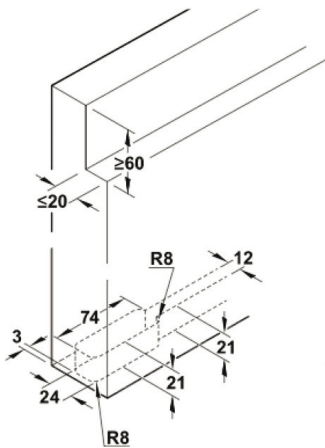

With end cap

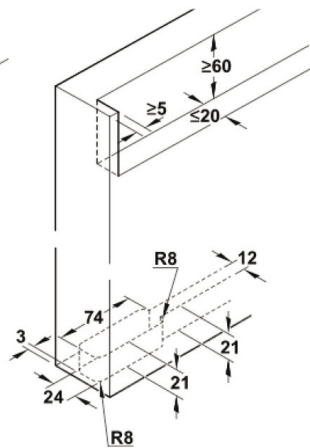

Concealed Installation



triline.  
net.au

Head Office/Factory  
86 Sunderland Street  
Derwent Park TAS 7009

1300 239 206  
sales@triline.net.au

[linkedin.com/company/triline](https://www.linkedin.com/company/triline)  
[facebook.com/trilinequalitydoorsystems](https://www.facebook.com/trilinequalitydoorsystems)

@trilinedoors  
triline.net.au